

# Three-Way Thermostatic Valves

1/2", 3/4", 1", 1-1/2" & 2" NPT Ports\*

## Features

- Self-Contained
- Wide Range of Temperatures
- Rugged Construction
- Non-Adjustable
- Heavy Duty
- Operate in Any Position
- Tamper-Proof
- Replaceable Element
- Compact

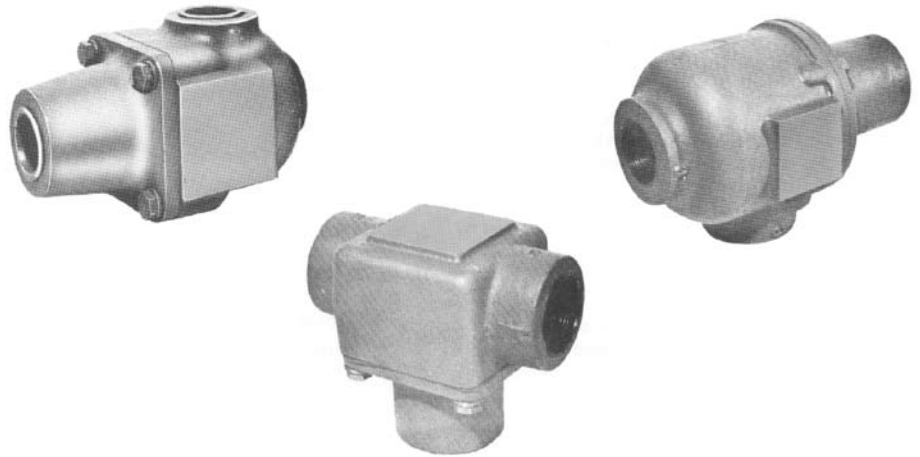

## Materials

**Housing** Grey Iron (steel or bronze optional)  
125 PSI maximum operating pressure

**O-Ring Seals** Viton (Buna N optional)

\*3", 4" and 6" Flange Models also available.

## Operation

TTP thermostatic valves use the principle of expanding wax. A self-contained power element activates a stainless steel sliding valve that provides a positive three-way valve action. All temperature settings are factory set. Elements are field replaceable to obtain the same, or a new bypass temperature setting.

On starting, total flow is in the bypass mode. As the fluid temperature rises, some fluid is diverted to the cooling system. As fluid temperature continues to rise, more flow is diverted until the valve is fully stroked. At this point, all the flow is diverted to the cooler. With respect to temperature ranges, the "nominal" temperature represents the "operating temperature." The first figure in the temperature range represents the valve opening point, and the second figure represents the full open point.

Valves are acceptable for oil or water service.

## Applications

Three Way Thermostatic Valves may be installed for either mixing or diverting modes of operation at the preference of the user. They may be mounted in any plane.

When installed as a mixing valve, it is on the cold side of the application, and mixes hot liquid with cooled liquid to discharge the proper temperature fluid to the process.

When installed as a diverting valve, it is on the hot side of the application, and bypasses the cold liquid allowing the system to warm up, then directs the hot liquid to the cooler.

Temperature settings are nominal. 110°F and 140°F are standard. Other settings are available upon request. The valves begin to "shift" (open) about 10°F below the nominal temperature setting and are fully shifted about 10°F above.

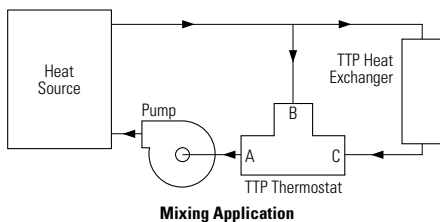

Mixing Application

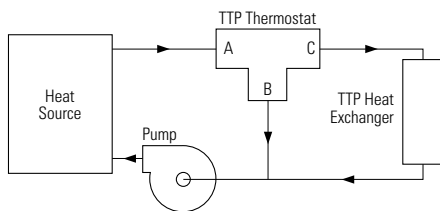

Diverting Application

## Typical Installation

**Hydraulic Power Units** Diverting mode 110°F

**Air Compressors** Mixing mode 140°F

**Mobile Oil Coolers** Diverting mode 110°F

**Radiators** Diverting mode 190°F

# Three-Way Thermostatic Valves

## Pressure Drop Curves

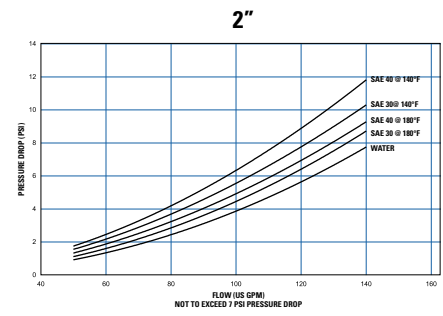
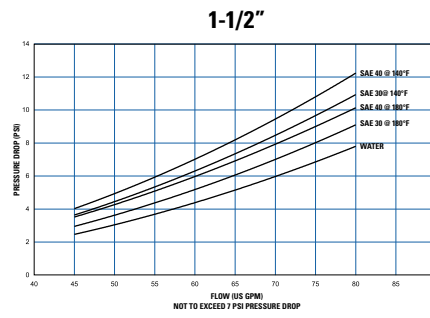
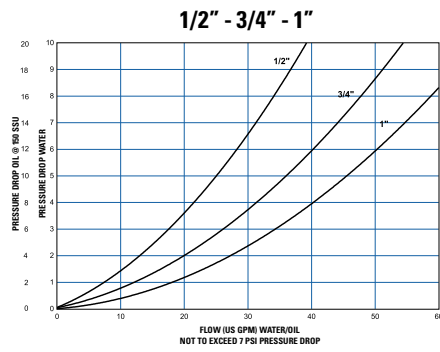

## Dimensions and Part Numbers

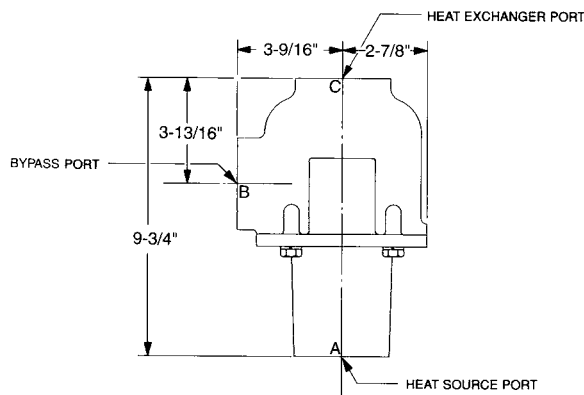
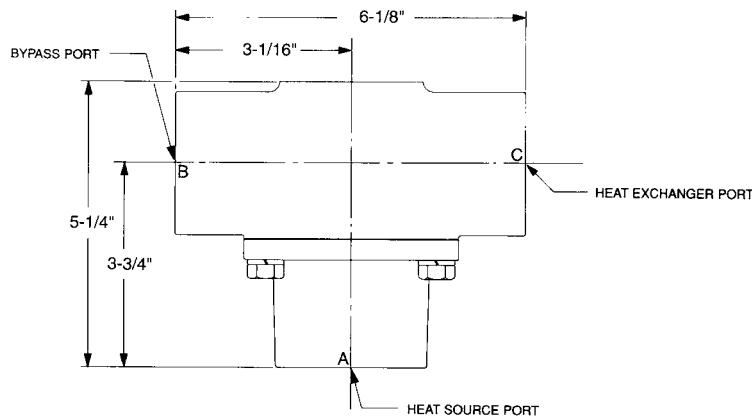
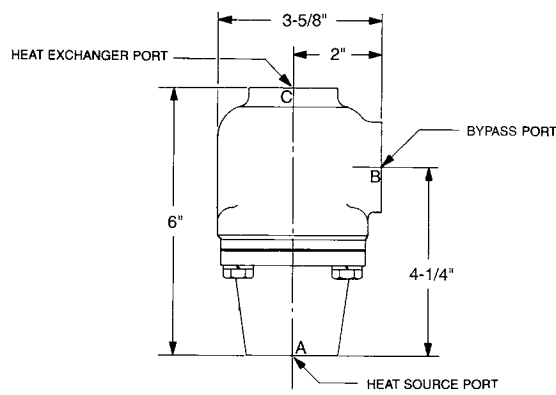

PORT SIZE	PART NUMBER
1/2" NPT	66037-110°F
1/2" NPT	66037-140°F
3/4" NPT	66038-110°F
3/4" NPT	66038-140°F
1" NPT	66039-110°F
1" NPT	66039-140°F
#16 SAE	67365-110°F
#16 SAE	67365-140°F

PORT SIZE	PART NUMBER
1-1/2" NPT	66040-110°F
1-1/2" NPT	66040-140°F
#24 SAE	67760-110°F

PORT SIZE	PART NUMBER
2" NPT	66041-105°F
2" NPT	66041-140°F

*NOTE: All three ports on any one valve have the same thread size.*

# Three-Way Thermostatic Valves

## Special Temperature Ranges

1/2"– 3/4"– 1" NPT PART NUMBERS	1 1/2" NPT PART NUMBERS	2" NPT PART NUMBERS
65974	65977	65978
65975	66040	66041
65976	67760	
66037	(#24 SAE)	
66038		
66039		
67365		
(#16 SAE)		

1/2"– 3/4"– 1" NPT		1 1/2" NPT		2" NPT	
NOMINAL	TEMPERATURE RANGE (°F)	NOMINAL	TEMPERATURE RANGE (°F)	NOMINAL	TEMPERATURE RANGE (°F)
80	77-88	80	70-88	75	70-85
90	80-100	90	80-100	90	85-105
110	100-120	110	100-120	105	100-116
120	110-130	120	110-130	120	110-130
130	120-140	130	120-140	130	124-140
140	130-150	140	130-150	140	135-150
150	140-160	150	140-160	150	145-160
160	150-170	160	150-170	155	150-165
170	163-180	170	163-180	160	155-172
185	175-190	175	170-185	165	160-175
195	185-200	180	175-190	170	165-180
200	190-210	190	185-200	180	175-190
		200	190-210	195	188-208
				210	200-215

EXAMPLE: 1" NPT, Part Number 66039-90 indicates the 1" NPT valve with a nominal shift temperature of 90°F. The actual operating temperature range in this example is 80-100°F. The valve begins to open at 80°F, and is fully open at 100°F.